

Kawahara's ROLL LAMINATOR



Model : KW-RL1

Specification

- 1) Roller Temperature : $110^{\circ} \text{ C} \pm 5^{\circ} \text{ C}$
- 2) Roller Size : Dia. 80 (mm) x 600 (mm) L
- 3) Silicone Rubber Coatir : 4 (mm)t
- 4) Roller Feeding Speed : 2.9 m/min Max. Speed Control Motor
- 5) Machine Size : 935w x 500h x 310d (mm)
- 6) Machine Weight : About 50kg

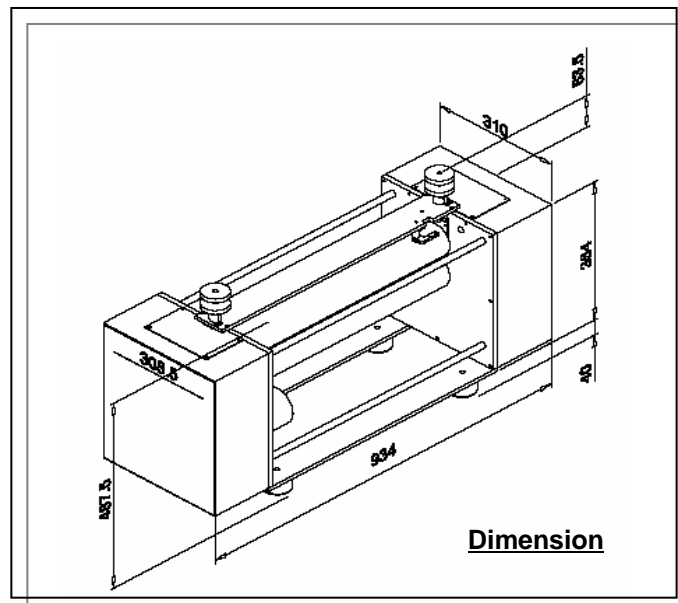

KAWAHARA
ENGINEERING WORKS SDN BHD
(Co. No. 412286-P)

Material Handling System & Factory Automation

KAWAHARA ENGINEERING WORKS SDN BHD

No.3, Jalan SC2, Pusat Perindustrian Sg. Chua,
43000 Kajang, Selangor Darul Ehsan, Malaysia

Tel : 603-8739-9672 Fax : 603-8739-9673

E-mail : kewsb@pd.jaring.my